

CARS

Part 7
SPRINGS
SHOCK ABSORBERS
WHEELS
120, 1800

SERVICE MANUAL

CONTENTS

| | |
|--|----|
| Specifications | 1 |
| Tools | 3 |
| GROUP 73, SPRINGS | |
| Description | 4 |
| Removing the front springs | 4 |
| Check-measuring | 5 |
| Replacing the rear springs | 5 |
| GROUP 76, SHOCK ABSORBERS AND STABILIZING DEVICES | |
| Description | 9 |
| Design | 9 |
| Function | 9 |
| Checking the shock absorbers | 10 |
| Replacing the front shock absorbers | 10 |
| Replacing the rear shock absorbers | 10 |
| Installing the shock absorbers | 11 |
| Replacing the support arm bushes | 12 |
| Replacing the torque rod bushes | 12 |
| Replacing the support rod bushes | 12 |
| Replacing the track rod bushes | 13 |
| GROUP 77, WHEELS | |
| Changing the wheels | 16 |
| Replacing the wheel studs | 16 |
| Replacing and adjusting the front wheel bearings | 16 |

SPECIFICATIONS

SPRINGS

Front springs

| | |
|-----------------------------|-----------------------------|
| Type | Coil spring |
| Material thickness | 14.1—14.3 mm (0.555—0.563") |
| External diameter | 121.0—122.5 mm (4.76—4.82") |
| Total number of turns | 8.7 |

Test values:

| | |
|---|----------------------------|
| Loading for a compression of 1 cm (0.4") (measured within a spring length of 175—215 mm=6.89—8.46") | 47.8—51.8 kg (105—114 lb.) |
| Length when fully compressed | max. 120 mm (4.72") |
| Loading for a spring length of 195 mm (7.68") | 481—511 kg (1058—1126 lb.) |

Rear springs, standard

| | P 120 2- and 4-door | P 120 Station Wagon | 1800 |
|--|--------------------------------|----------------------------------|--------------------------------|
| Type | Coil spring | | |
| Material thickness | 11.7—11.9 mm (0.461—0.469") | 12.28—12.48 mm (0.483—0.491") | 11.2—11.4 mm (0.441—0.449") |
| External diameter | 114.5—116.0 mm (4.51—4.57") | 127.5—129.0 mm (5.02—5.08") | 116.0—117.5 mm (4.57—4.63") |
| Total number of turns | 10.7 | 9.2 | 10.7 |
| Test values: | | | |
| Loading for a compression of 1 cm (0.4") | 19.4—21.4 kg (43—47 lb.) | 18.5—20.5 kg (41—45 lb.) | 16.1—17.7 kg (35—39 lb.) |
| measured within a spring length of | 225—265 mm (8.86—10.43") | 227—267 mm (8.94—10.51") | 225—265 mm (8.86—10.43") |
| Length when fully compressed | max. 123 mm (4.84") | max. 110 mm (4.33") | max. 118 mm (4.64") |
| Loading | 276—294 kg (609—649 lb.) | 276—294 kg (609—649 lb.) | 229—234 kg (504—515 lb.) |
| for a spring loading of | 245 mm (9.65") | 247 mm (9.72") | 245 mm (9.65") |

Rear springs, extra

| | 120 2- and 4-door | 120 Station Wagon |
|--|--------------------------------|----------------------------------|
| Type | Coil spring | |
| Material thickness | 12.3—12.5 mm (0.484—0.492") | 12.77—12.97 mm (0.502—0.510") |
| External diameter | 115.0—116.5 mm (4.53—4.77") | 127.5—129.0 mm (5.02—5.08") |
| Total number of turns | 10.7 | 9.5 |
| Test values: | | |
| Loading for a compression of 1 cm (0.4") | 23.4—25.4 kg (51.5—56 lb.) | 22.4—24.4 kg (49—54 lb.) |
| measured within a spring length of | 225—265 mm (8.86—10.43") | 245—285 mm (9.65—11.22") |
| Length when fully compressed | Max. 129 mm (5.10") | Max. 119 mm (4.69") |
| Loading | 342 kg (750 lb.) | 273—297 kg (601—653 lb.) |
| for a spring loading of | 245 mm (9.65") | 265 mm (10.43") |

SHOCK ABSORBERS

| | | | |
|--|---|----------------------------|----------------------------|
| Type | Double-acting, hydraulic telescopic shock absorbers | | |
| Overall length | | | |
| front shock absorber, compressed | approx. 300 mm (11.81") | approx. 300 mm (11.81") | approx. 305 mm (12.0") |
| extended | approx. 415 mm (16.34") | approx. 415 mm (16.34") | approx. 425 mm (16.73") |
| rear shock absorber, compressed | approx. 355 mm (13.98") | approx. 270 mm (10.63") | approx. 356 mm (14.02") |
| extended | approx. 530 mm (20.87") | approx. 428 mm (16.85") | approx. 526 mm (20.71") |

WHEELS

Wheel rims

| | | | |
|---------------------------------------|--------------------------------------|--------------------------------------|-------------------------------|
| | P 120 2- and 4-door | P 120 Station Wagon | P 1800 |
| Type | Disc | Disc | Disc |
| Designation | 4J × 15 | 4½J × 15 | 4½J × 15L |
| Number of wheel nuts | 5 | 5 | 5 |
| Radial throw | max. 2.5 mm (0.10") | max. 2.5 mm (0.10") | max. 1.8 mm (0.07") |
| Run-out | max. 2.5 mm (0.10") | max. 2.5 mm (0.10") | max. 2.5 mm (0.10") |
| Out-of-balance (complete wheel) | max. 900 gcm (0.87 lb.in.) | max. 900 gcm (0.87 lb.in.) | max. 900 gcm (0.87 lb.in.) |
| Wheel nut tightening torque | 10—14 kgm (70—100 lb.ft.) | 10—14 kgm (70—100 lb.ft.) | 10—14 kgm (70—100 lb.ft.) |

TYRES

| | | | |
|----------------------------|--|-----------------|-----------------|
| Type | Types 1 and 4 with tubes, types 2 and 3 tubeless | | |
| Size, type 1 | 5.90 × 15"-4 PR | 6.40 × 15"-6 PR | 165 SR 15"-4 PR |
| type 2 | 6.00 × 15"-4 PR | 6.40S15"-6 PR | |
| type 3 | 165S15"-4 PR | | |
| type 4 ²⁾ | 165SR15"-4 PR | | |

Tyre pressure table

| | | 5.90 × 15" | | 6.00 × 15" 165S15" | | 6.40 × 15" 6.40S15" | | 165 SR 15" | |
|------------------|-------|--------------------|------------------|-----------------------|------------------|------------------------|--------|--------------------|--------|
| | | kg/cm ² | p.s.i. | kg/cm ² | p.s.i. | kg/cm ² | p.s.i. | kg/cm ² | p.s.i. |
| With 1—2 persons | Front | 1.4 ¹⁾ | 20 ¹⁾ | 1.4 ¹⁾ | 20 ¹⁾ | 1.6 | 23 | 1.8 | 26 |
| | Rear | 1.6 | 23 | 1.6 | 23 | 2.0 | 28 | 2.2 | 26 |
| Full load | Front | 1.4 ¹⁾ | 20 ¹⁾ | 1.5 | | 1.6 | 23 | 1.8 | 26 |
| | Rear | 1.8 | 26 | 2.0 | 28 | 2.5 | | 2.2 | |

- 1) With 5.90 × 15", 6.00 × 15", 165S15", 6.40 × 15" and 6.40S15" tyres, the pressure should be increased by 0.3 kg/cm² (4 p.s.i.) for prolonged driving at speeds above 140 km.p.h. (90 m.p.h.). The pressure must, however, never exceed 2.1 kg/cm² (30 p.s.i.) for 4 PR tyres and 2.5 kg/cm² (35 p.s.i.) for 6 PR tyres.
- 2) Applies only to 123 GT.

TOOLS

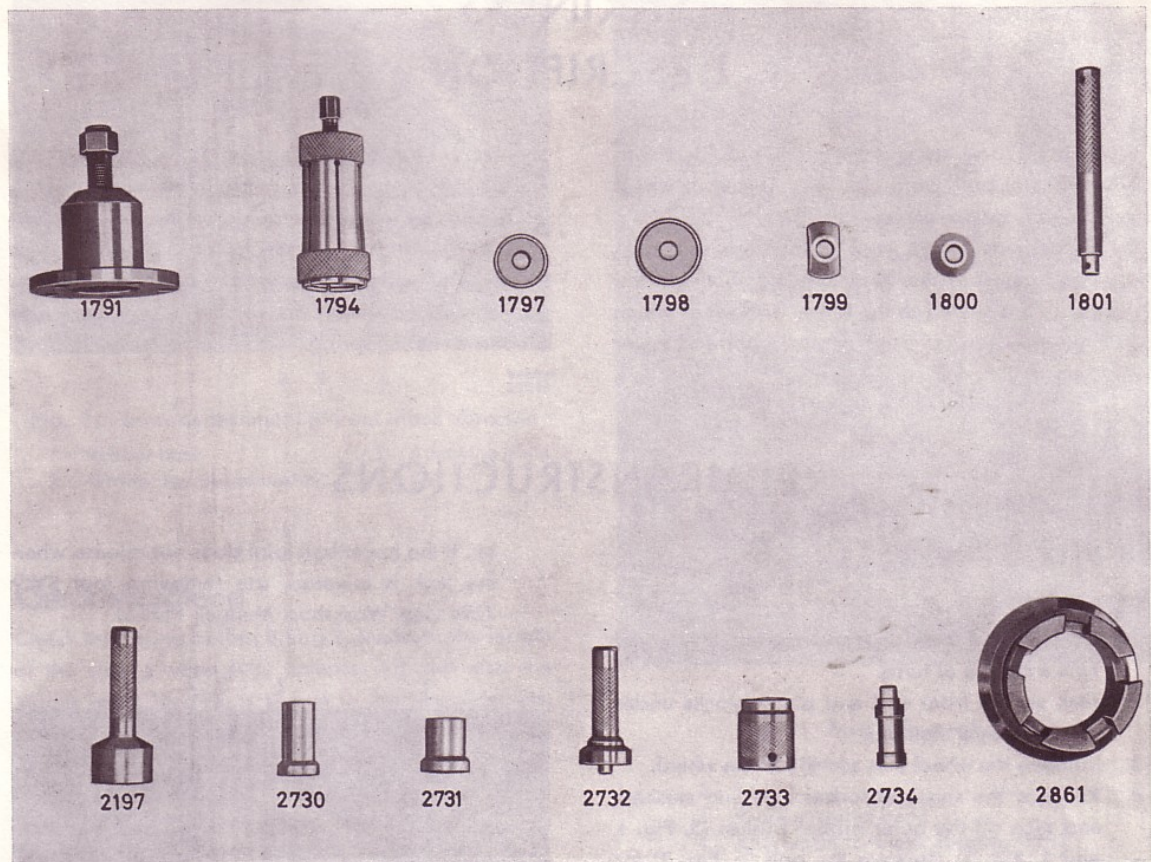

SVO 1791 Puller for wheel hub

SVO 1794 Puller for inner ring inner wheel bearing

SVO 1797 Drift for fitting outer bearing ring

SVO 1798 Drift for fitting inner bearing ring and seal in hub

SVO 1799 Drift for removing inner bearing ring

SVO 1800 Drift for removing bearing ring

SVO 1801 Standard handle 18×200 mm

SVO 2197 Drift for removing and fitting grease cap

SVO 2730 Drift for pressing in and out support track front bush, bush for right side track rod and plated bushes for support rod on 120 Station Wagon, also for torque rod front bush (120) and for plated bushes for support rod on 120 late prod.

SVO 2731 Drift for pressing in and out bush for track rod left side on 120 Station Wagon

SVO 2732 Drift for pressing in and out rear bush for torque rod 120 late prod.

SVO 2733 Counterhold for pressing bushes in and out

SVO 2734 Drift for pressing bushes with "waist" in and out of support rod on late prod. 120-series and 1800

SVO 2861 Tool for changing wheel studs

GROUP 73

SPRINGS

DESCRIPTION

The Volvo 120-series and 1800 are provided with coil springs at both front and rear. The front wheel suspension is independent.

The upper ends of the front springs are seated in housings formed in the front axle member and the lower ends are seated in the lower wishbones which are fitted between the front axle member and lower ball joint.

The upper ends of the rear springs on 120 and 1800 are located by means of a guide in the body and the lower ends by means of a guide on the rear axle. On the 120 Station Wagon the lower ends of the rear springs are located by means of a guide on the support arm. In addition, this vehicle is provided with a hollow rubber spring.

REPAIR INSTRUCTIONS

FRONTS SPRINGS

Removing

1. Remove the hub cap and loosen the wheel nuts a couple of turns.
2. Jack up the front end and place blocks under the front axle member.
3. Remove the wheel nuts and lift off the wheel.
4. Remove the shock absorber nuts and washers and take off the outer rubber bushes (3, Fig. 1 and 1, Fig. 2). Remove the bolt (4, Fig. 2) for the attaching plate (3) and pull this together with the shock absorber downwards.
5. Place a jack centrally under the spring and jack up until the rubber buffer of the upper wishbone lifts.
6. Disconnect the stabilizer from the lower wishbone. Remove the nut (12, Fig. 1) for the lower ball joint.
7. Lower the jack slowly and remove the spring when the wishbone has come down sufficiently

far. If the lower ball joint does not release when the jack is lowered, use removing tool SVO 2294 (see Workshop Manual, Part 6).

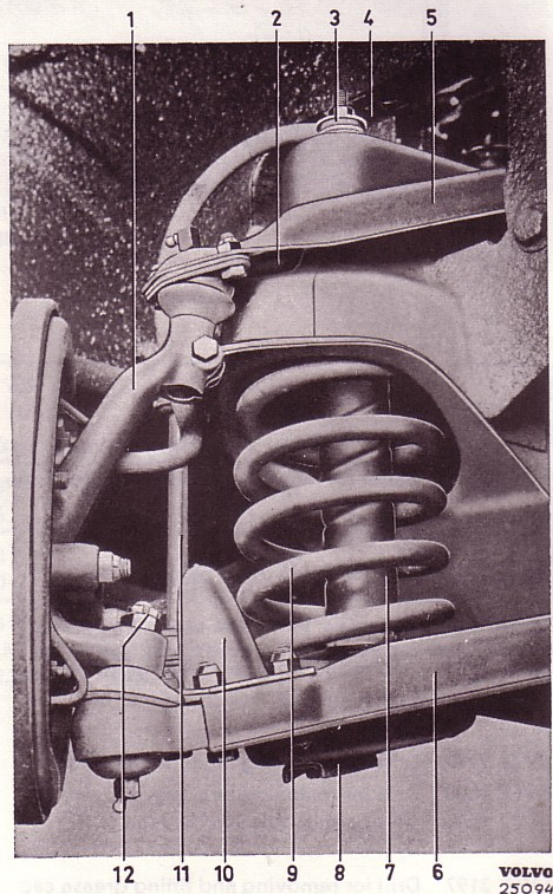

Fig. 1. Front spring and shock absorber

1. Steering knuckle
2. Upper rubber buffer
3. Rubber bush
4. Washer
5. Upper wishbone
6. Lower wishbone
7. Shock absorber
8. Attaching plate
9. Spring
10. Lower rubber buffer
11. Stabilizer
12. Nut for lower ball joint

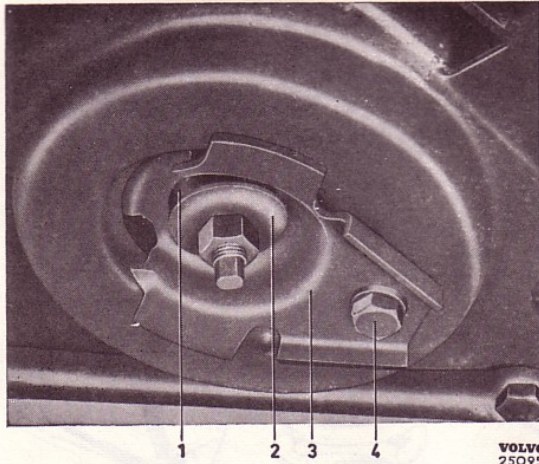

Fig. 2. Lower attachment of front shock absorber

- | | |
|---------------------------|--------------------|
| 1. Rubber bush | 3. Attaching plate |
| 2. Washer for rubber bush | 4. Bolt |

Check-measuring

Check the spring before fitting it. Measure the length of the spring when fully compressed and also the length when loaded as shown in the specifications. Also check the rubber spacer (9, Fig. 6).

Installing

Place the rubber spacer (9, Fig. 8) and washer (10) in position in the spring housing in the front axle member and fit the spring in the reverse order to removal.

REAR SPRINGS

Removing

1. Jack up the rear end of the car and place blocks under the rear jacking points.
2. Remove the wheels and release the handbrake.
3. Place a jack under the rear axle casing and jack up until the shock absorber bands slacken.
- 4a. Volvo 120 2- and 4-door, 1800:
Loosen the lower shock absorber attachment (Figs 6 and 7) and the upper attachment for the shock absorber band (6, Figs. 6 and 7) on both sides. Slacken the front attachments of the support arms slightly.

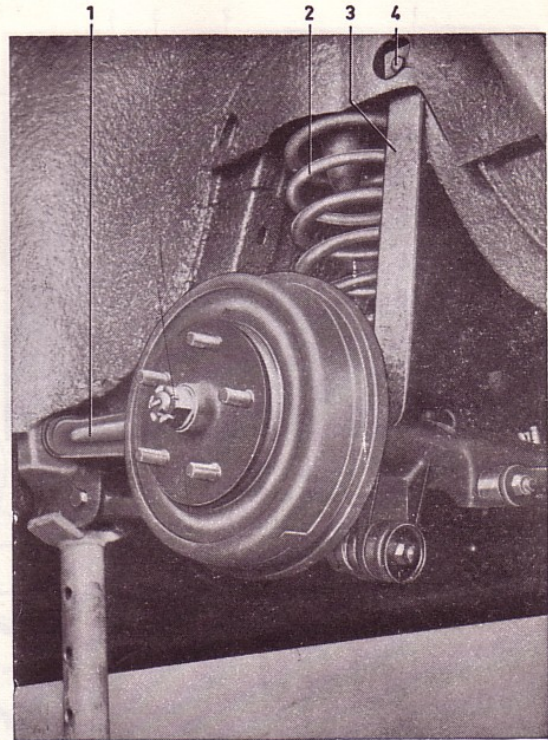

Fig. 3. Rear axle, early prod.

- | |
|---------------------------------------|
| 1. Support arm |
| 2. Spring |
| 3. Shock absorber band |
| 4. Attachment for shock absorber band |

4b. Station Wagon:

Loosen the lower attachment for the shock absorber (Fig. 5) and the lower attachment for the shock absorber band (9, Fig. 5) on both sides.

5. Lower the rear axle until the spring is free and then remove the spring and spacer.

Check measuring

See under "Front springs, Check-measuring".

Installing

Installing is done in the reverse order to removing. Make sure that the rubber pad (11, Figs. 6 and 7) and the rubber spacer (4, Figs. 6 and 7) come into the correct position.

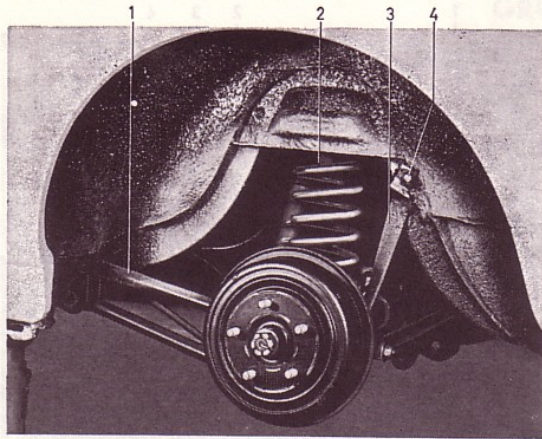

VOLVO
102694

Fig. 4. Rear axle, late prod.

1. Support stay
2. Spring
3. Shock absorber band
4. Attachment for shock absorber band

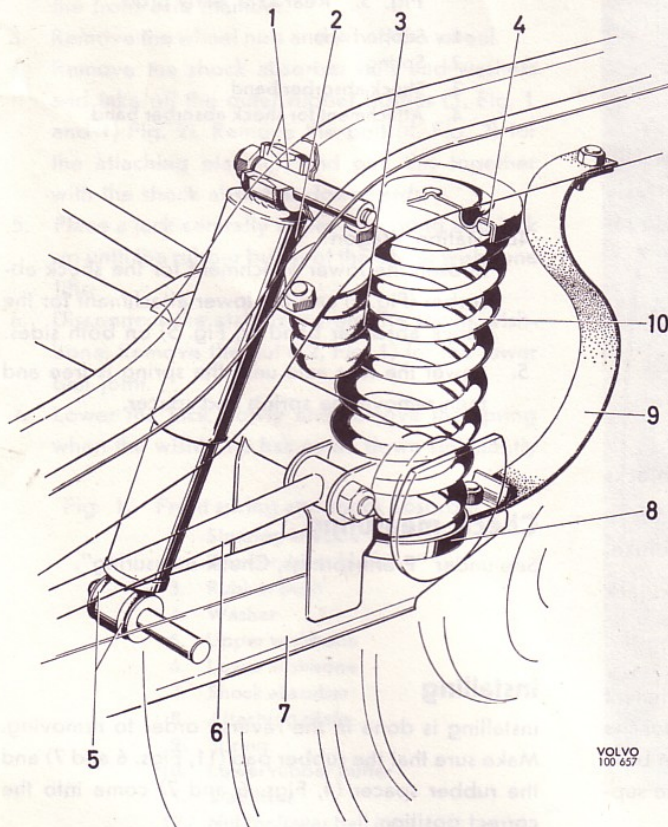

VOLVO
100627

Fig. 5. Rear axle suspension,
120 Station Wagon

1. Rubber bushes, upper shock absorber attachment
2. Shock absorber
3. Hollow rubber spring
4. Rubber spacer
5. Rubber bushes, lower shock absorber attachment
6. Support arm
7. Support stay
8. Lower spring seat
9. Shock absorber band
10. Spring

7-6

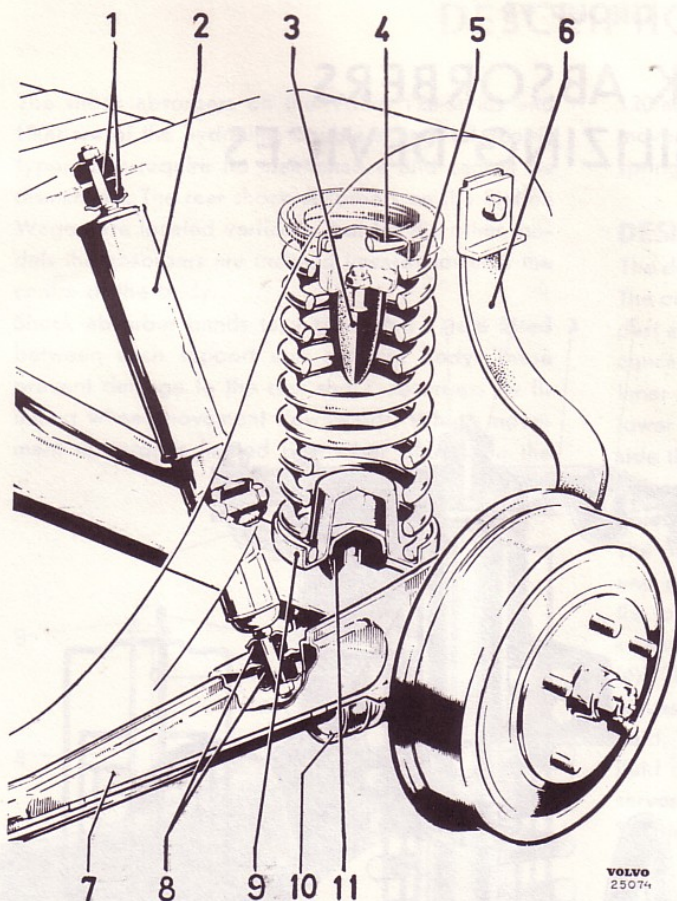

Fig. 6. Rear axle suspension, 120, 1800, early prod.

1. Rubber bushes, upper shock absorber attachment
2. Shock absorber
3. Rubber buffer
4. Rubber spacer
5. Spring
6. Shock absorber band
7. Support arm
8. Rubber bushes, lower shock absorber attachment
9. Spring seat
10. Torque rod
11. Rubber pad

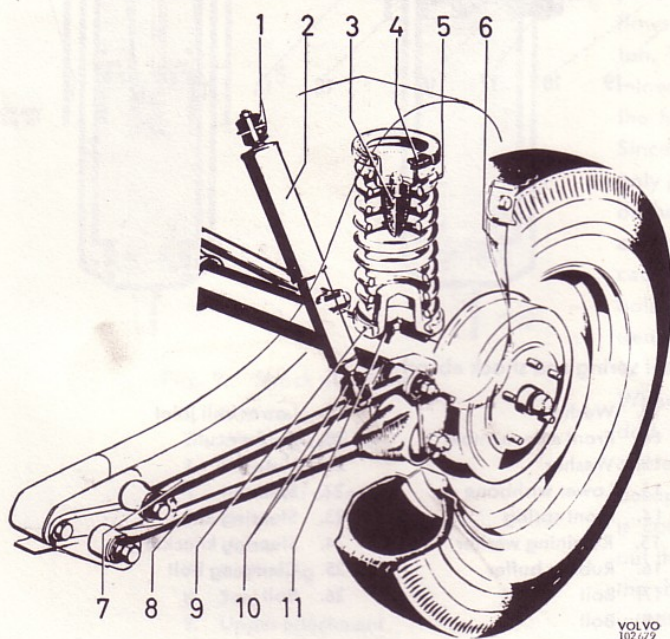

Fig. 7. Rear axle suspension, 120, 1800, late prod.

1. Rubber bushes, upper shock absorber attachment
2. Shock absorber
3. Rubber buffer
4. Rubber spacer
5. Spring
6. Shock absorber band
7. Support stay
8. Torque rod
9. Spring seat
10. Rubber bushes, lower shock absorber attachment
11. Rubber pad

GROUP 76

SHOCK ABSORBERS
AND STABILIZING DEVICES

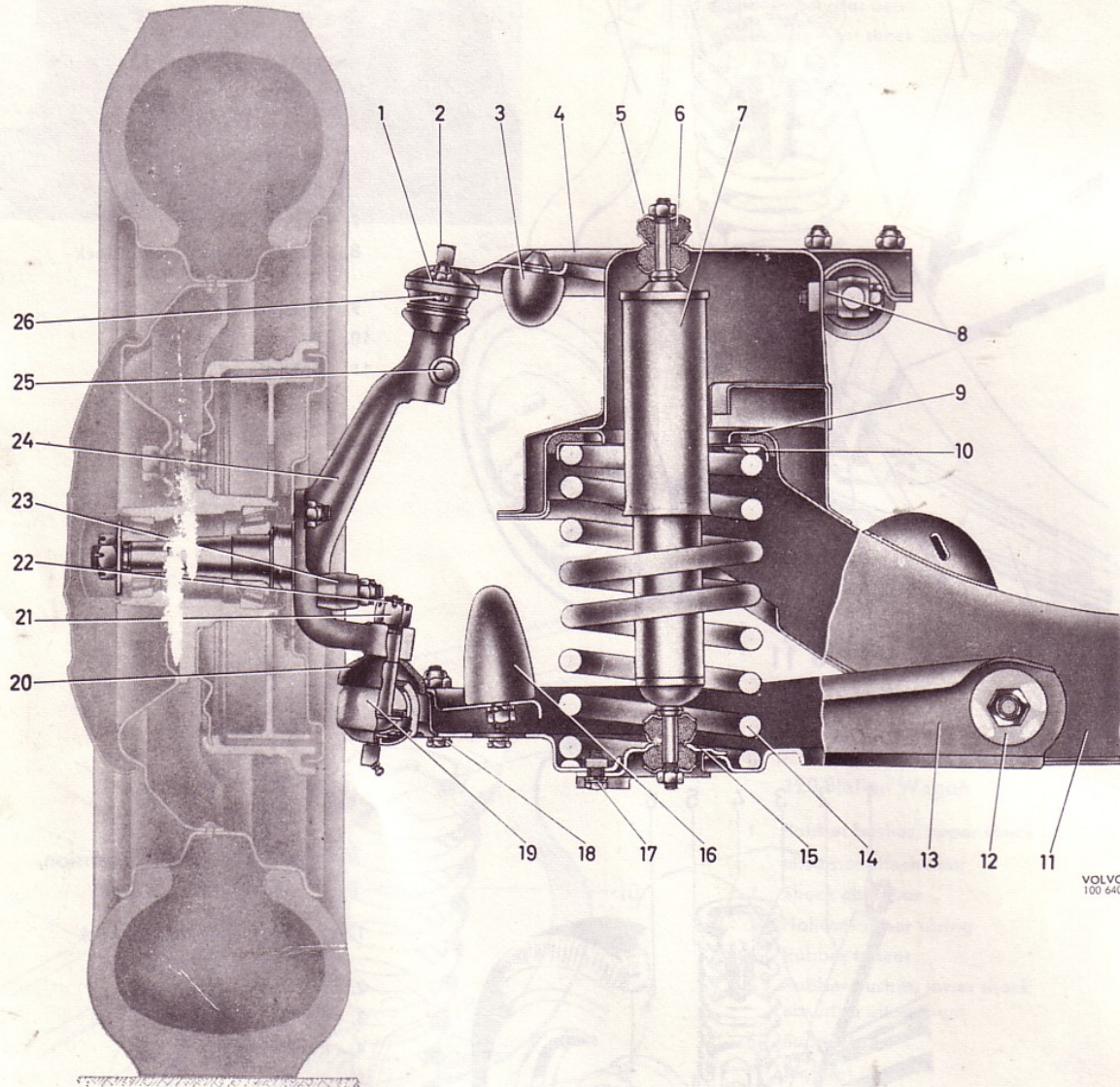

Fig. 8. Front spring and shock absorber

- | | | |
|---------------------|-----------------------|----------------------|
| 1. Upper ball joint | 10. Washer | 19. Lower ball joint |
| 2. Grease nipple | 11. Front axle member | 20. Rubber cuff |
| 3. Rubber buffer | 12. Washer | 21. Nut |
| 4. Upper wishbone | 13. Lower wishbone | 22. Split pin |
| 5. Washer | 14. Front spring | 23. Steering arm |
| 6. Rubber bush | 15. Retaining washer | 24. Steering knuckle |
| 7. Shock absorber | 16. Rubber buffer | 25. Clamping bolt |
| 8. Shims | 17. Bolt | 26. Bolt |
| 9. Rubber spacer | 18. Bolt | |

DESCRIPTION

The shock absorbers on the Volvo 120-series and 1800 are of the hydraulic, double-acting, telescopic type. They require no maintenance and cannot be dismantled. The rear shock absorbers on the Station Wagon are located vertically, but for the other models the absorbers are inclined inwards towards the centre of the body.

Shock absorber bands (3, Figs. 3 and 4) are fitted between each support arm and the body. These prevent damage to the rear shock absorbers by limiting wheel movement downwards. Wheel movement upwards is limited by rubber buffers on the

120 and 1800. On the 120 Station Wagon, the wheel movement upwards is limited by a hollow rubber spring.

DESIGN

The design of the shock absorbers is shown in Fig. 9. The outer cylinder serves only as a protection against dust and dirt. The other two cylinders (2) and (4) are concentrically arranged, one inside the other. The inner cylinder (2) is the actual working cylinder, the lower end of which is provided with a valve (6). Inside the inner cylinder there is a piston (5) in which holes are drilled, the passage of oil through these holes being controlled by valves.

The piston is attached to a piston rod (3), the upper end of which forms an attachment to the body. At the opposite end of the shock absorber a similar screw attachment is fitted to the reservoir cylinder (4). The space between the cylinders (2) and (4) serves as a reservoir and is only partially filled with fluid. The inner cylinder (2) is completely filled with fluid on both sides of the piston (5). The cover (8) serves as a seal and a guide for the piston rod (3). The ring (7) acts as a baffle for the fluid.

FUNCTION

When the shock absorber is compressed or extended depending on the suspension load of the vehicle, the piston (5) moves in the inner cylinder (2). Fluid then flows through the valve-controlled holes in the piston. The speed at which the piston moves is determined by the rate at which the fluid passes through the holes from one side of the piston to the other. Since the drilled holes are very narrow, the fluid can only pass through slowly, thus braking the movement of the piston. When the shock absorber is suddenly compressed or extended, a further braking effect is caused by turbulence in the fluid passing through the holes in the piston. This dampens any rolling tendency on the part of the vehicle and ensures smoother riding.

When the shock absorber is compressed or extended, the volume on each side of the piston is not altered by the same amount since the piston rod occupies a certain space. When the shock absorber is compressed, therefore, some of the fluid passes out through the valve (6) into the reservoir and when the shock absorber is extended, fluid is again sucked into the cylinder (2) on the other side of the piston.

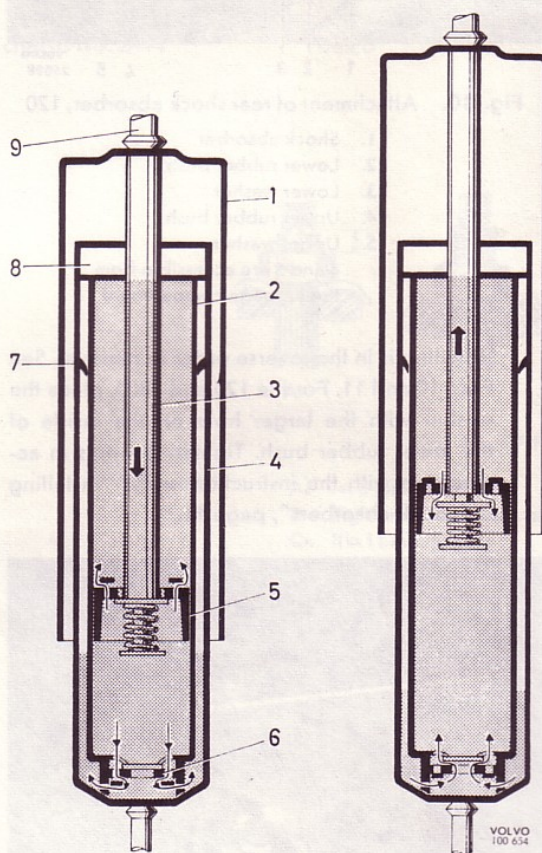

Fig. 9. Shock absorber

1. Dust cover
2. Working cylinder
3. Piston rod
4. Reservoir cylinder
5. Piston
6. Valve
7. Baffle ring
8. Seal
9. Upper attachment

REPAIR INSTRUCTIONS

CHECKING THE SHOCK ABSORBERS

A simple way of checking the condition of the shock absorbers is to rock the car up and down and then release it. The damping effect of the shock absorbers can be observed during this operation. Testing can also be carried out by driving the vehicle over a bumpy road surface.

If the shock absorber has been removed from the vehicle, the low attachment should be tightly clamped in a position similar to that when fitted on the vehicle. By then quickly pulling out and alternately compressing the shock absorber, it is possible to judge whether it functions at all. However, the damping effect can only be definitely decided with the help of special test devices.

When checking shock absorbers, note that the resistance on extending the absorbers is normally about 3 times greater than when compressing, due to the structure of the absorber.

Shock absorbers that do not function properly in both directions must be replaced. Worn or damaged rubber bushes should also be replaced.

REPLACING THE FRONT SHOCK ABSORBERS

1. Remove the upper attaching nut, washer (5, Fig. 10) and rubber bush (4).
2. Remove the lower attaching nut, washers and rubber bush. See 2 and 3 (Fig. 10).
3. Remove the bolt (4, Fig. 2) for the lower washer (3) in the lower wishbone and pull out the washer and shock absorber.
4. Installing is in reverse order to removal. Place the washers as shown in Fig. 8. Tighten the nuts in accordance with the instructions under "Installing the shock absorbers".

REPLACING THE REAR SHOCK ABSORBERS

1. Remove the upper attaching nut, washer and rubber bush (120 model) from the luggage compartment (Fig. 10) and for the 1800 model through the hole (Fig. 11) in the hat shelf under the rear window.
For removal of the shock absorbers on the 120 Station Wagon, see Fig. 13.
2. Remove the lower attaching nut, washers and rubber bush. Remove the shock absorber.

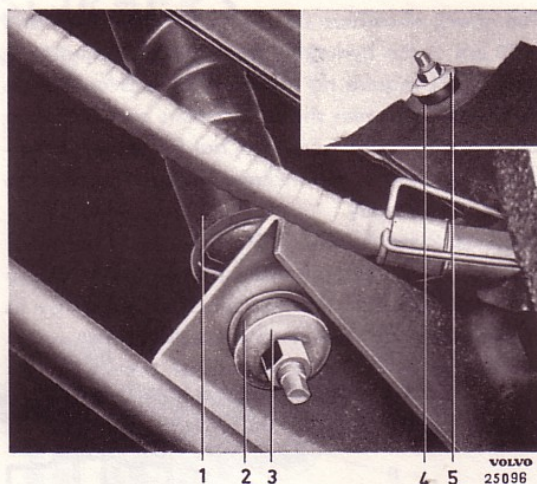

Fig. 10. Attachment of rear shock absorber, 120

1. Shock absorber
 2. Lower rubber bush
 3. Lower washer
 4. Upper rubber bush
 5. Upper washer
- 4 and 5 are accessible from the luggage compartment

3. Installing is in the reverse order to removal. See Figs. 10 and 11. For the 120 and 1800, place the washer with the larger hole on the inside of the lower rubber bush. Tighten the nuts in accordance with the instruction under "Installing the shock absorbers", page 11.

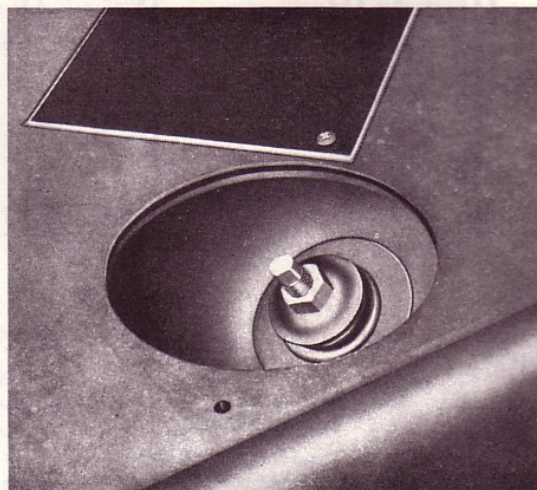

Fig. 11. Upper attachment of rear shock absorber, 1800

INSTALLING THE SHOCK ABSORBERS

Some types of shock absorber attachments have the retaining nut screwed directly on the shock absorber rod. Since the tightening of this nut can vary with the

vehicle type and shock absorber type, the following information is given for those types of shock absorbers fitted on our vehicles (see Fig. 12).

| Vehicle model | Make | Measurement III (Fig. D) | Fitted as shown in Fig. |
|-------------------------------|--------------------|--------------------------|-------------------------|
| 120 | Delco, early prod. | 44 mm (1.73") | A |
| " | Delco, late prod. | 49 mm (1.93") | B |
| " | Gabriel, type I | 44 mm (1.73") | A |
| " | Gabriel, type II | 52 mm (2.05") | C ₁ |
| " | Gabriel, type III | 49 mm (1.93") | C ₂ |
| 1800 up to chassis No. 2443 | Gabriel, type I | 44 mm (1.73") | A |
| | Gabriel, type II | 52 mm (2.05") | C ₁ |
| 1800 w.e.fr. chassis No. 2444 | Delco | 44 mm (1.73") | A |

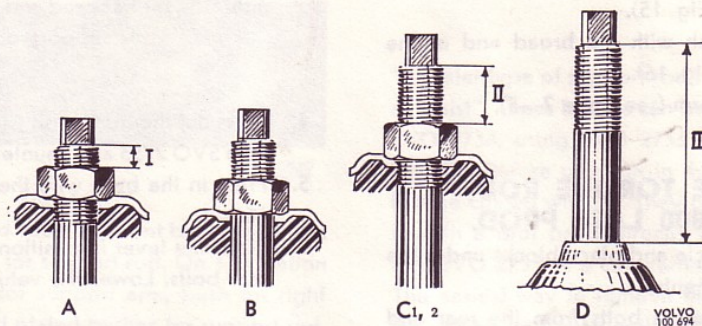

Fig. 12. Fitting shock absorbers

- A. I=3 mm (0.118")
- B. Tightened to bottom of thread
- C₁. II=11 mm (0.43")
- C₂. II=9 mm (0.36")
- D. III=The distance varies according to the type of shock absorber, see table above

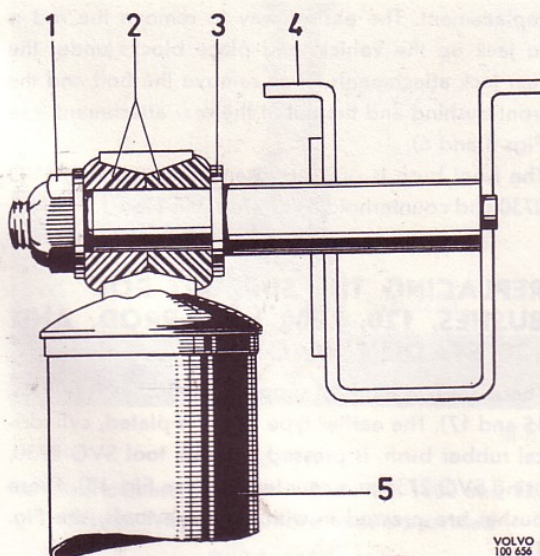

Fig. 13. Shock absorber, 120 Station Wagon

- 1. Nut
- 2. Rubber bush
- 3. Washer
- 4. Frame

REPLACING THE SUPPORT ARM BUSHES, 120, 1800 EARLY PROD. AND 120 STATION WAGON

The support arms on the 120 and 1800 do not have any bushes which have to be pressed in or out (see Figs. 3 and 6). The easiest way to replace the bushes is to jack up the vehicle, place blocks under the rear jack attachments and remove the wheel. Let the jack remain under the rear axle while the work is in progress.

However, the front support arm bush on the 120 Station Wagon must be pressed out as follows:

1. Remove the rear springs according to "Removing the rear springs", page 7—5.
2. Remove the rubber suspension for the rear axle.
3. Remove the bolt and front bush and take off the support arm.
4. Press out the bush with the narrow end of tool SVO 2730 (see Fig. 15).
5. Press in the bush with the broad end of the same tool (see Fig. 16).
6. Fit the support arm (see page 7—5).

REPLACING THE TORQUE ROD BUSHES, 120, 1800 LATE PROD.

1. Jack up the vehicle and place blocks under the rear jack attachments.
2. Remove the through bolts from the rear and front bush, take off the rod (see Figs. 4 and 7).
3. Press out the rear bush with drift SVO 2732 (see Fig. 14). The bush is pressed in with the same tool. For a late prod. type rubber bush with a "waist", the rubber should be coated with oil before pressing in the bush.

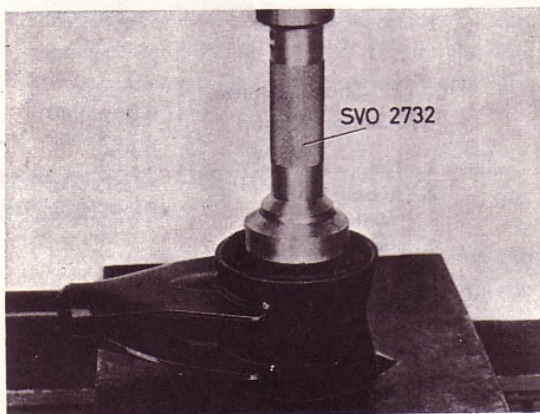

Fig. 14.

Removing and fitting the rear bush on torque rod, 120, 1800 late prod.

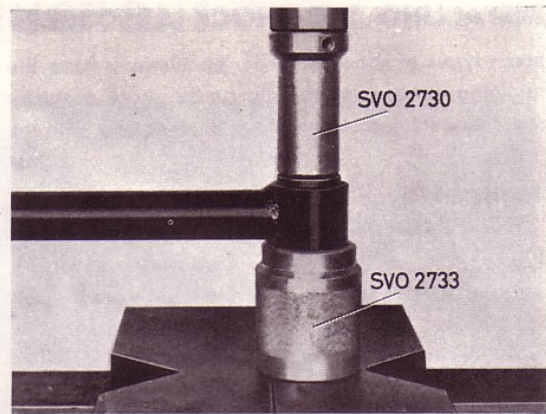

Fig. 15.

Removal of: On 120 and 1800, front bush for torque rod and plated bush for support rod. On 120 Station Wagon, the front bush for support arm, the bush on right side for track rod and plated bushes for support rod.

4. Press out the front bush with drift SVO 2730 and with SVO 2733 as a counterhold (see Fig. 15).
5. Press in the bush with the same tools, see Fig. 16.
6. Place the lever in position and fit the front and rear bolts. Lower the vehicle.

REPLACING THE TORQUE ROD BUSHES, 120, 1800 EARLY PROD.

For the torque rod on older vehicles, only the front bush requires to be pressed out. The rear bushes consist of rubber pads which are merely slid off for replacement. The easiest way to remove the rod is to jack up the vehicle and place blocks under the rear jack attachments. Then remove the bolt and the front bushing and the nut at the rear attachment (see Figs 3 and 6).

The front bush is pressed in and out with drift SVO 2730 and counterhold SVO 2733, see Figs. 15 and 16.

REPLACING THE SUPPORT ROD BUSHES, 120, 1800 LATE PROD. AND 120 STATION WAGON

There are two types of support rod bushes (see Figs. 15 and 17). The earlier type with the plated, cylindrical rubber bush, is pressed out with tool SVO 2730, using SVO 2733 as a counterhold (see Fig. 15). These bushes are pressed in with the same tools, see Fig. 16.

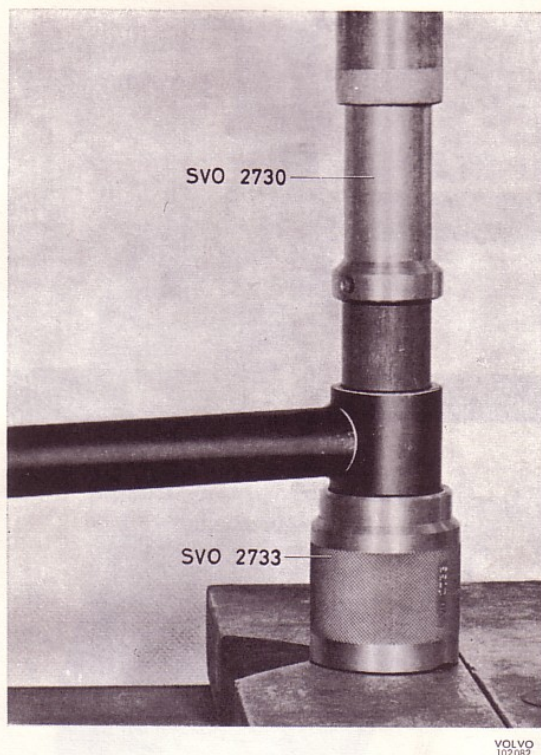

Fig. 16.

Fitting of: On 120 and 1800, the front bush for torque rod and plated bush for support rod. On 120 Station Wagon, front bush for support arm, bush on right side for track rod and plated bushes for support rod.

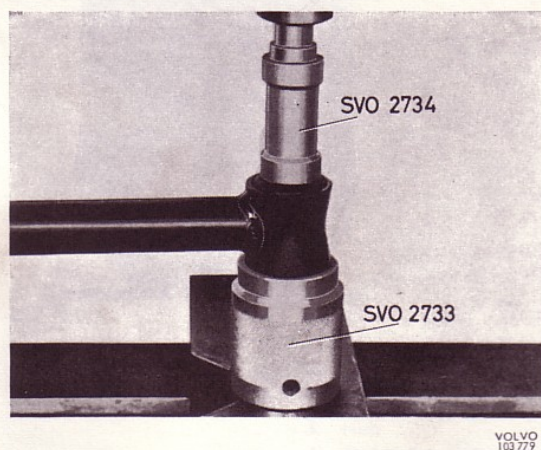

Fig. 17.

Removal of bush for track rod on 120, 1800 and 120 Station Wagon where the bush is provided with a "waist".

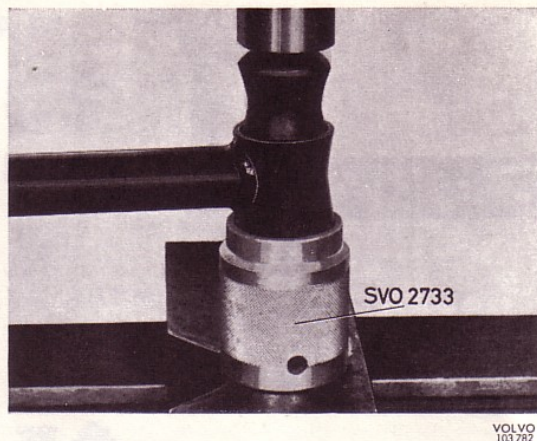

Fig. 18.

Fitting of bush for support rod on 120, 1800 and 120 Station Wagon where the bush is provided with a "waist".

The later type of support rod has rubber bushes with a "waist". These bushes can be pressed out with tool SVO 2734, using SVO 2733 as a counterhold (see Fig. 17). Before pressing in the bushes, they should first be coated with oil. They can be suitably pressed in with a drift press directly on the bush and with tool SVO 2733 as a counterhold (see Fig. 18).

The easiest way to remove these rods is to jack up the vehicle and remove the wheels.

REPLACING THE TRACK ROD BUSHES, 120, 1800, 120 STATION WAGON

The bushes for the track rod on the 120 and 1800 can be replaced without using a press. The bushes should be coated with a little oil before being pressed in by hand. N.B. The bush which should be fitted to the right in the vehicle should have a metal bush inside the rubber one.

On the other hand, the track rod for the 120 Station Wagon has plated rubber bushes which must be pressed out. The bushes are in different dimensions.

On the right side which has the small bush, use tool SVO 2730 to press out the bush and SVO 2733 as a counterhold (see Fig. 15). Pressing in is done with the same tools, see Fig. 16. On the left side, use tool SVO 2731 to press out with and SVO 2733 as a counterhold (see Fig. 19). Pressing in is done with the same tools, see Fig. 20.

The rods can be removed without having to take off any other components.

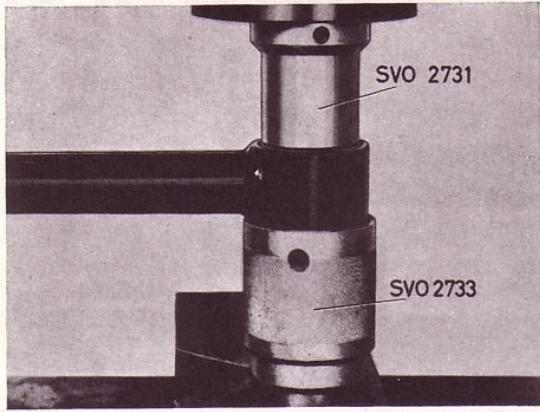

Fig. 19.

Removing the bush on track rod left side,
120 Station Wagon.

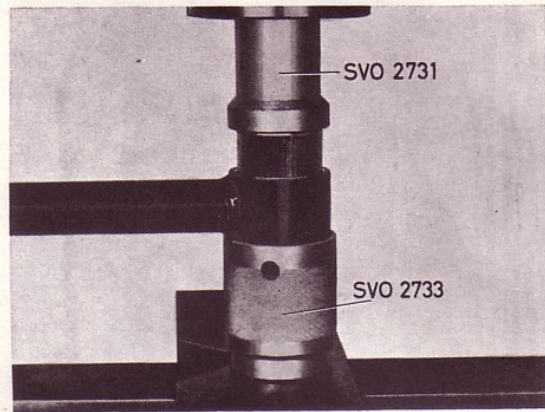

Fig. 20.

Fitting the bush on track rod left side,
120 Station Wagon.

GROUP 77
WHEELS
REPAIR INSTRUCTIONS

VOLVO
100 641

Bild 21.

- | | |
|------------------------------|-------------------------------|
| 1. Wheel rim | 7. Grease cap |
| 2. Hub cap | 8. Roller bearing, inner |
| 3. Hub | 9. Wheel nut |
| 4. Outer ring, outer bearing | 10. Outer ring, inner bearing |
| 5. Roller bearing, outer | 11. Seal |
| 6. Washer | |

CHANGING THE WHEELS

It is important to remember when changing wheels that any gravel or dirt should be removed from the contact surfaces between the wheel and hub, also any surplus paint on the new parts.

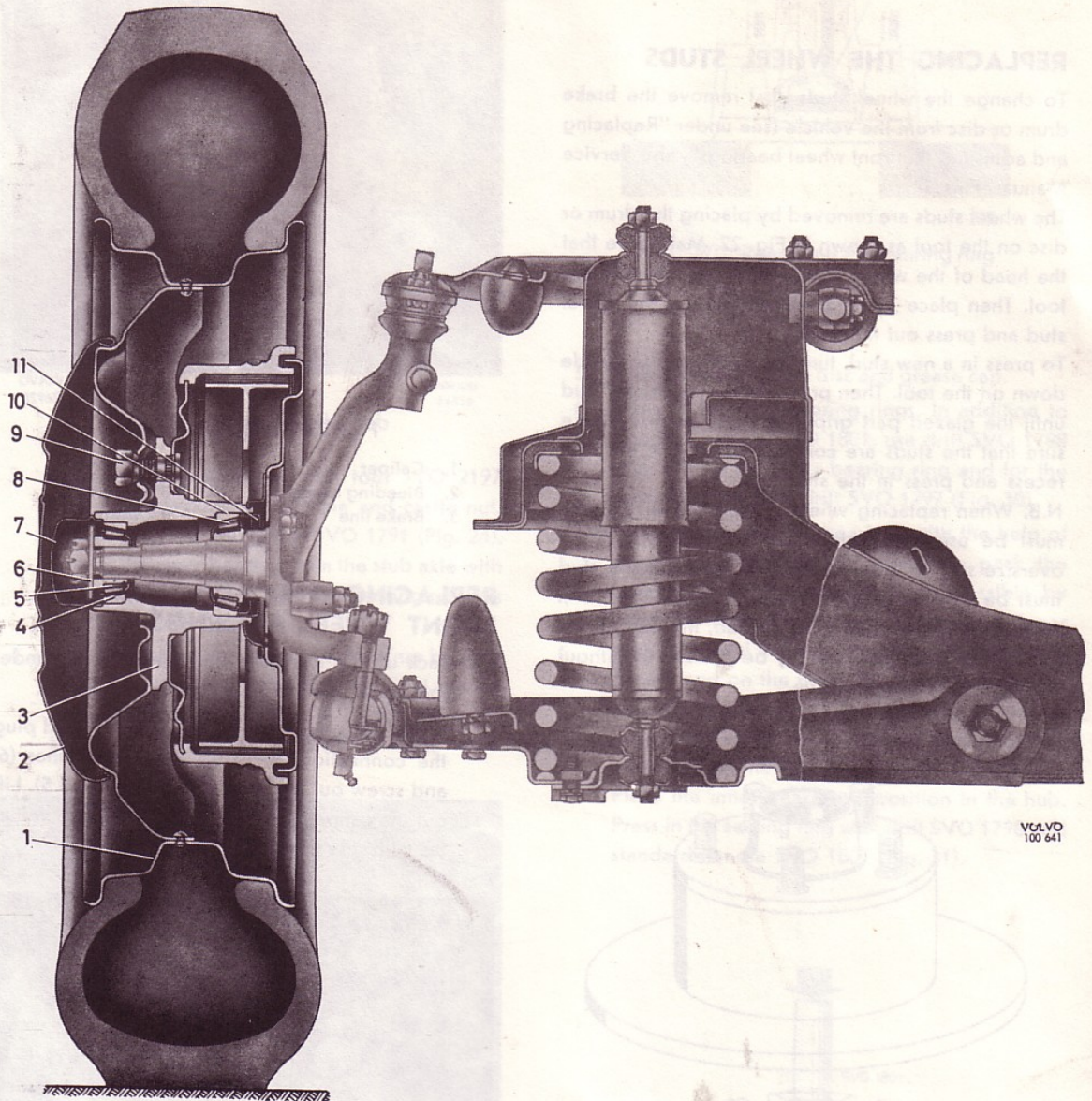
REPLACING THE WHEEL STUDS

To change the wheel studs, first remove the brake drum or disc from the vehicle (see under "Replacing and adjusting the front wheel bearings", also Service Manual, Part 5).

The wheel studs are removed by placing the drum or disc on the tool as shown in Fig. 22. Make sure that the head of the wheel studs enters the recess in the tool. Then place a drift press directly on the wheel stud and press out the stud.

To press in a new stud, turn the drum or disc upside down on the tool. Then press in the new wheel stud until the glazed part grips the drum or disc. Make sure that the studs are correctly located in the tool recess and press in the stud fully.

N.B. When replacing wheel studs, an oversize stud must be used to replace the old one. To fit an oversize stud in a brake disc, the hole for the stud must be drilled up to 16.5—16.7 mm (0.65—0.66"). As far as a brake drum is concerned, the new, oversize, wheel stud can generally be pressed in without having to machine the hole.

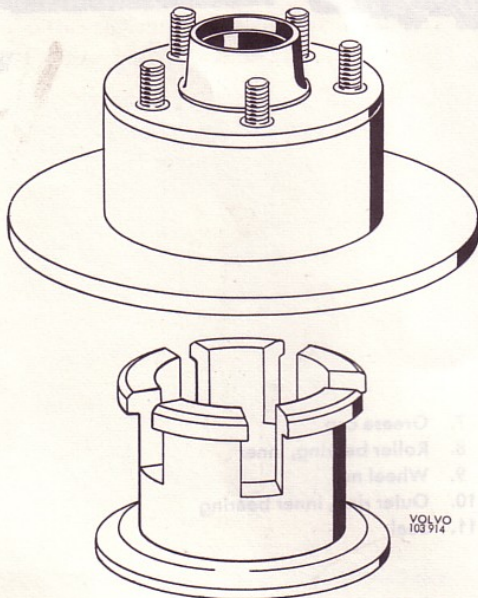
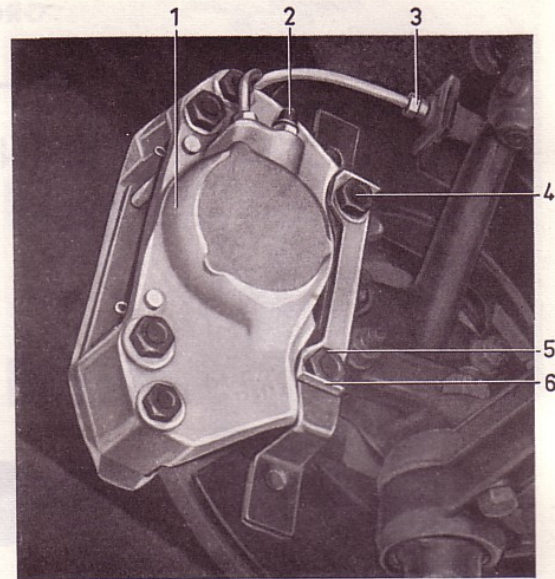

Fig. 22. Placing the brake disc on the tool



VOLVO
26928

Fig. 23. Front wheel brake

- | | |
|--------------------|-------------------|
| 1. Caliper | 4. Attaching bolt |
| 2. Bleeding nipple | 5. Attaching bolt |
| 3. Brake line | 6. Lock washer |

REPLACING AND ADJUSTING THE FRONT WHEEL BEARINGS

1. Jack up the front end and place blocks under the lower wishbones. Remove the wheel.
2. Screw loose the brake line (3, Fig. 23) and plug the connection. Bend up the lock washer (6) and screw out the attaching bolts (4 and 5). Lift out the caliper (1) complete. (Applies to vehicles with disc brakes.)



VOLVO
24558

Fig. 24. Removing the grease cap

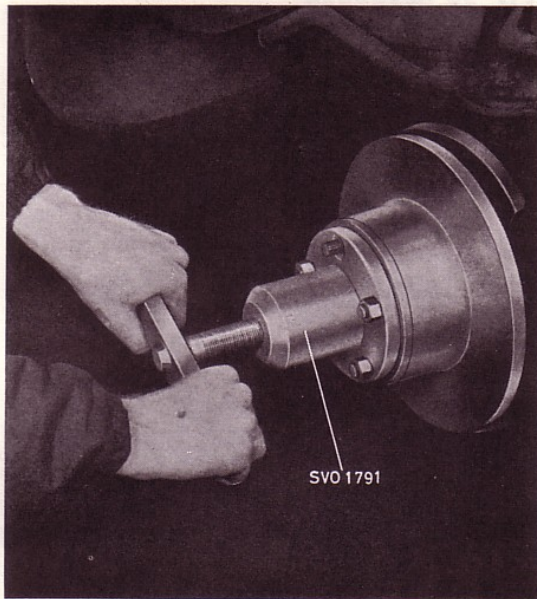

Fig. 25. Removing the hub

3. Remove the grease cap with tool SVO 2197 (Fig. 24). Remove the split pin and castle nut. Pull off the hub with puller SVO 1791 (Fig. 24). Pull off the inner bearing from the stub axle with puller SVO 1794 (Fig. 26) if the bearing remains in position.
4. Remove the bearing rings. For the inner bearing ring, use drift SVO 1799 (Fig. 27), and for the outer bearing ring, drift SVO 1800 (Fig. 28) together with standard handle SVO 1801.



Fig. 26. Removing the inner bearing

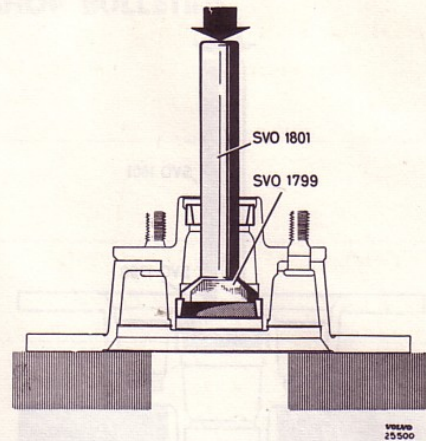

Fig. 27. Removing the bearing ring

5. Clean the hub, brake disc and grease cap.
6. Press in the new bearing rings. In addition to standard handle SVO 1801, use drift SVO 1798 (Fig. 29) for the inner bearing ring and for the outer bearing ring, drift SVO 1797 (Fig. 30).
7. Press grease into the bearings with the help of a greaser. If such is not available, pack the bearings with as much grease as possible by hand between the holder and bearing inner ring. Also coat the outsides of the bearings with grease and on the outer rings pressed into the hub. Fill the recess in the hub with grease all round and up to the smallest diameter on the outer ring for the outer bearing, see Fig. 32. Place the inner bearing in position in the hub. Press in the sealing ring with drift SVO 1798 and standard handle SVO 1801 (Fig. 31).

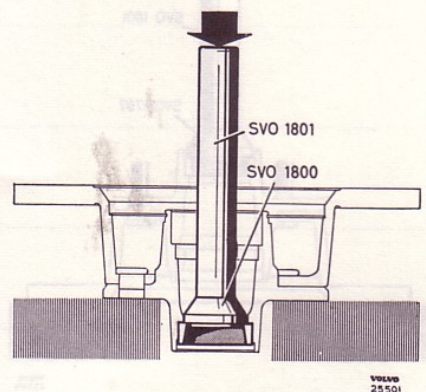

Fig. 28. Removing the outer bearing ring

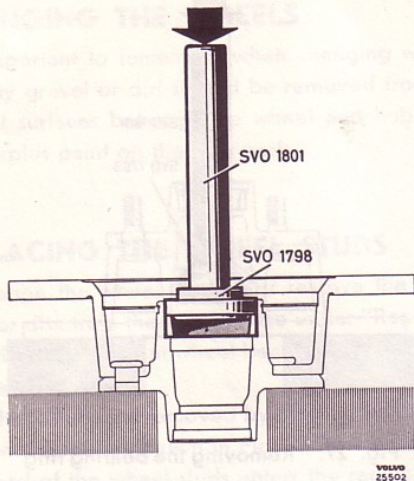

Fig. 29. Fitting the inner bearing ring

8. Place the hub on the stub axle. Fit the outer bearing, washer and castle nut.
9. The front wheel bearings are adjusted by first tightening the nut with a torque wrench to a torque of 7 kpm (50 lb.ft.), and then slackening the nut two hex flats. If the nut recess does not coincide with the split pin hole in the stub axle, release the nut further until the split pin can be fitted. Check that the wheel rotates easily without any play.

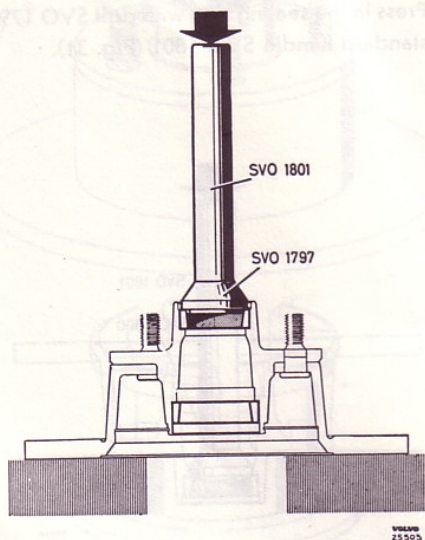

Fig. 30. Fitting the outer bearing ring

7—18

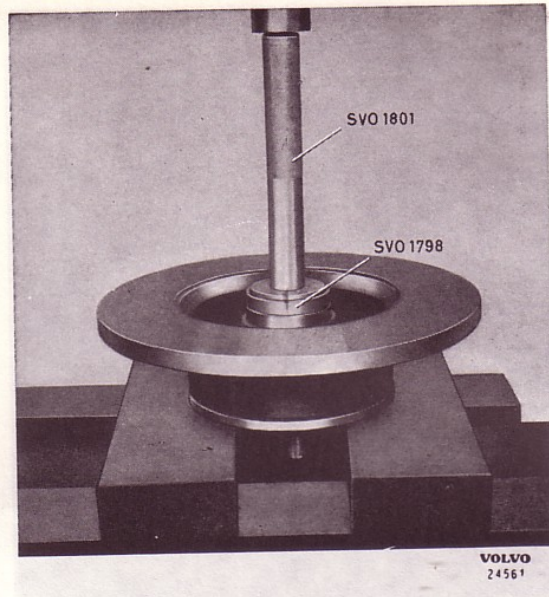

Fig. 31. Fitting the sealing ring

10. Fill half of the grease cap with grease and install with tool SVO 2197.
11. Fit the caliper and lock the attaching bolts. Connect up the brake line. Bleed the wheel cylinders, see Part 5. (Applies only to vehicles with disc brakes).
12. Refit the wheel. Make sure that the contact surfaces between wheel and hub are clean.

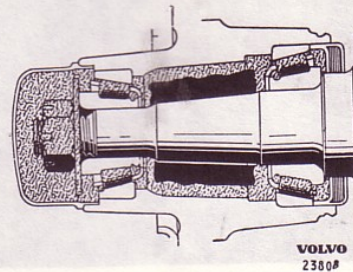
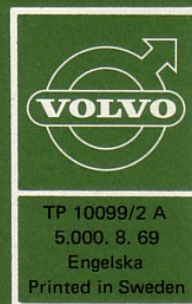

Fig. 32. Lubricating the front wheel bearing

REFERENCES TO WORKSHOP BULLETINS

A series of horizontal dotted lines for writing, spanning the width of the page.



Printed in Sweden, Gotab, Surte 71.6411